

# 3990 Pipe Cutter Operating Instructions

1. Open the drive screw all the way by turning the drive screw counterclockwise (to loosen) until flush with bottom of lower trunnion. Do not remove screw from lower trunnion threads.



2. Holding jaws as show, wrap chain under pipe to be cut. Pull chain up and over pipe, pulling cutter close to pipe.



3. Pull up on inside jaw set to open cutter. (Should appear like an open pair of scissors). Choose chain pin to engage the jaw pin. Engage chain pin in pocket located on the inside of the outer jaw.



4. Take up remaining slack with knurled handle on screw. (Turn screw clockwise to tighten). As the chain is tightened, the upper jaw and lower jaw will get closer together. Make sure there is a space between the upper jaw and lower jaw chain cutter wheels when chain is snug. If there is contact between these cutter wheels, and the chain is still loose, repeat Steps 1 thru 3. Squeeze jaws as shown and hand tighten the drive screw until snug.



5. Once the chain is snug, make sure that the cutter wheels do not touch. At any time during the cut, if cutter wheels are too far apart, cut will result with jagged edges.

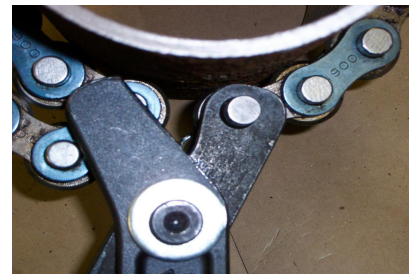

6. Once slack has been removed, place ratchet on square end of drive screw assembly. Keep turning ratchet clockwise to cut pipe.

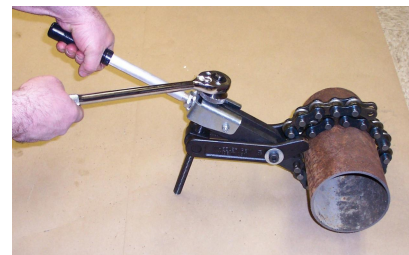

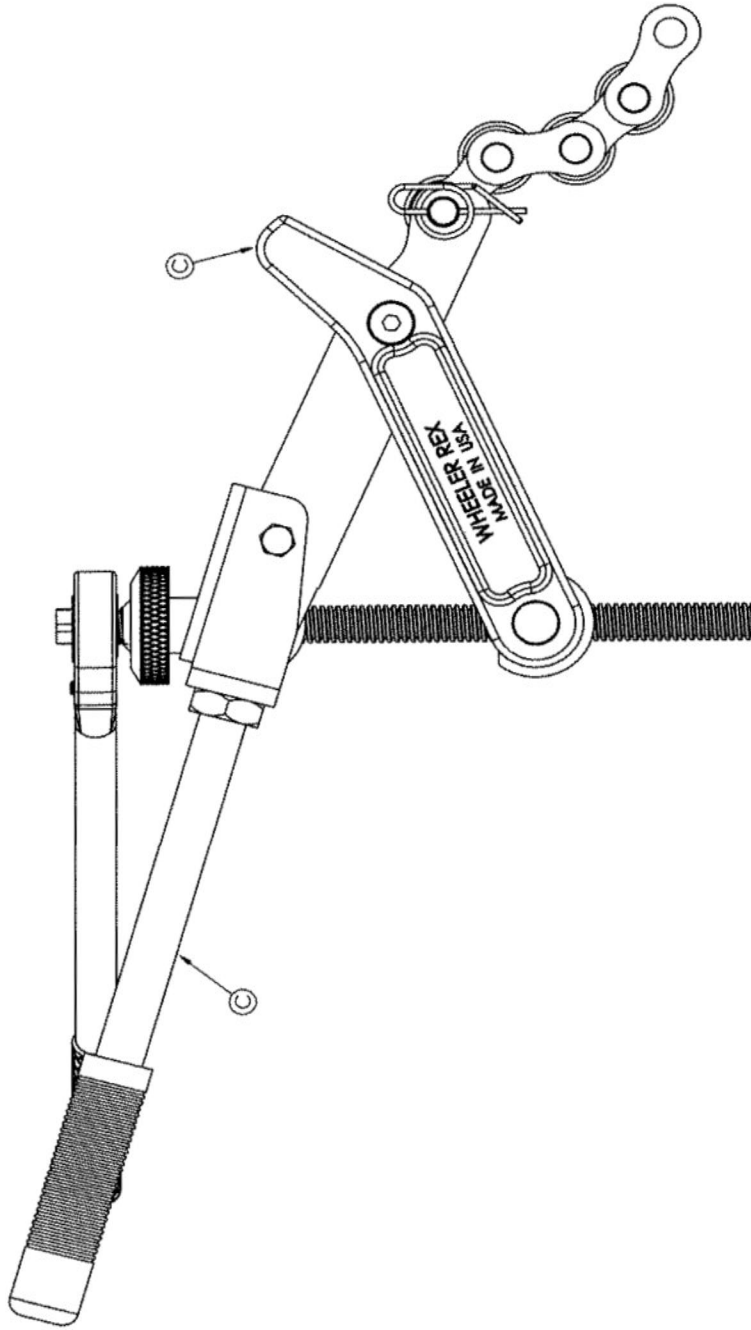
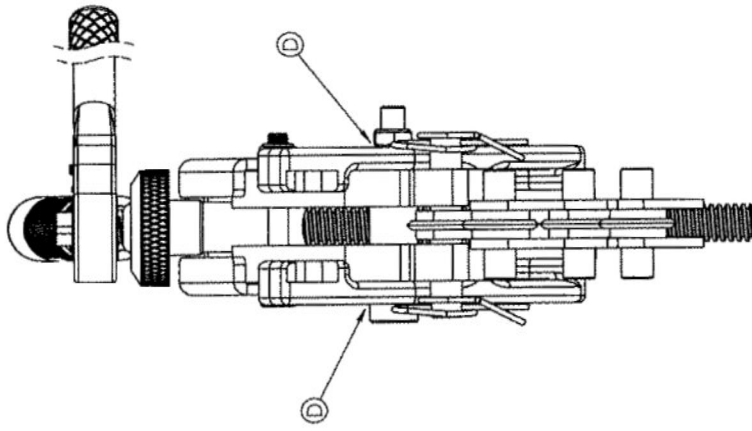

DESCRIPTION: RATCHET PIPE CUTTER

PART NO. 39906

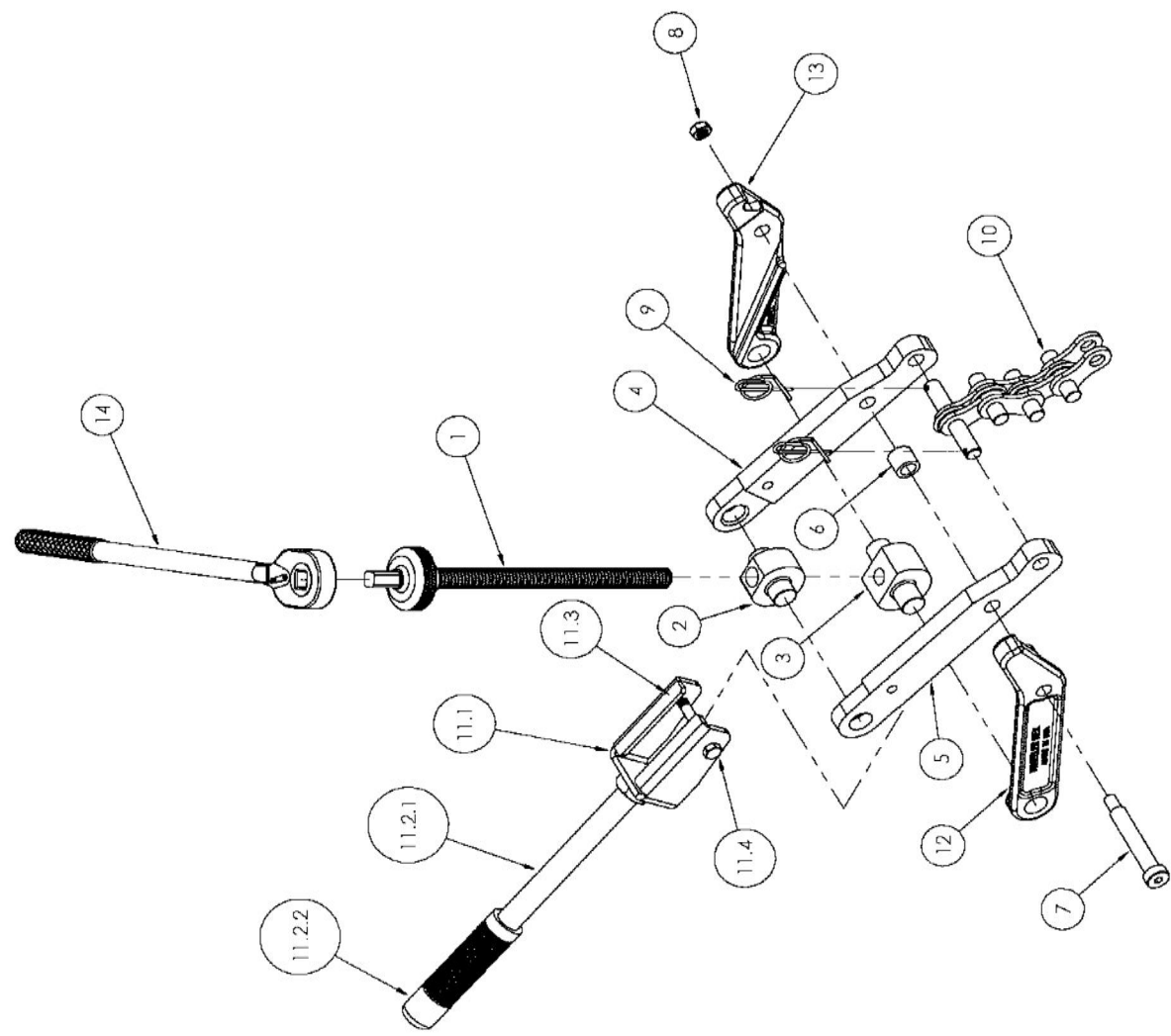

ITEM NO.	PART NUMBER	DESCRIPTION	QTY.
1	700919	DRIVE SCREW ASBY.	1
2	700917	UPPER TRUNION	1
3	700916	LOWER TRUNION	1
4	700914	LEFT HAND INNER JAW	1
5	700915	RIGHT HAND INNER JAW	1
6	2983	JAW SPACER LONG	1
7	275836	2 3/4" x 1/2" Socket Head Shoulder Screw	1
8	276198	3/8" Nylon-Insert Locknuts	1
9	3908	HAIR PIN CLIP	2
10	700987	6" CHAIN	1
11	701101	HANDLE ASSEMBLY	1
11.1	701100	STRAP ASSEMBLY	1
11.2	652	HANDLE ASBY	1
11.2.1	6526	HANDLE	1
11.2.2	154	GRIP	1
11.3	275857	5/16"-18 Thin Hex Nylon-Insert Locknuts	1
11.4	276737	5/16"-18 x 2 3/4" HEX HEAD CAP SCREW	1
12	700913	RIGHT HAND OUTER JAW	1
13	700912	LEFT HAND OUTER JAW	1
14	6520	RATCHET, 1/2" SQ. DRIVE	1



DESCRIPTION: RATCHET PIPE CUTTER  
 PART NO. 39906

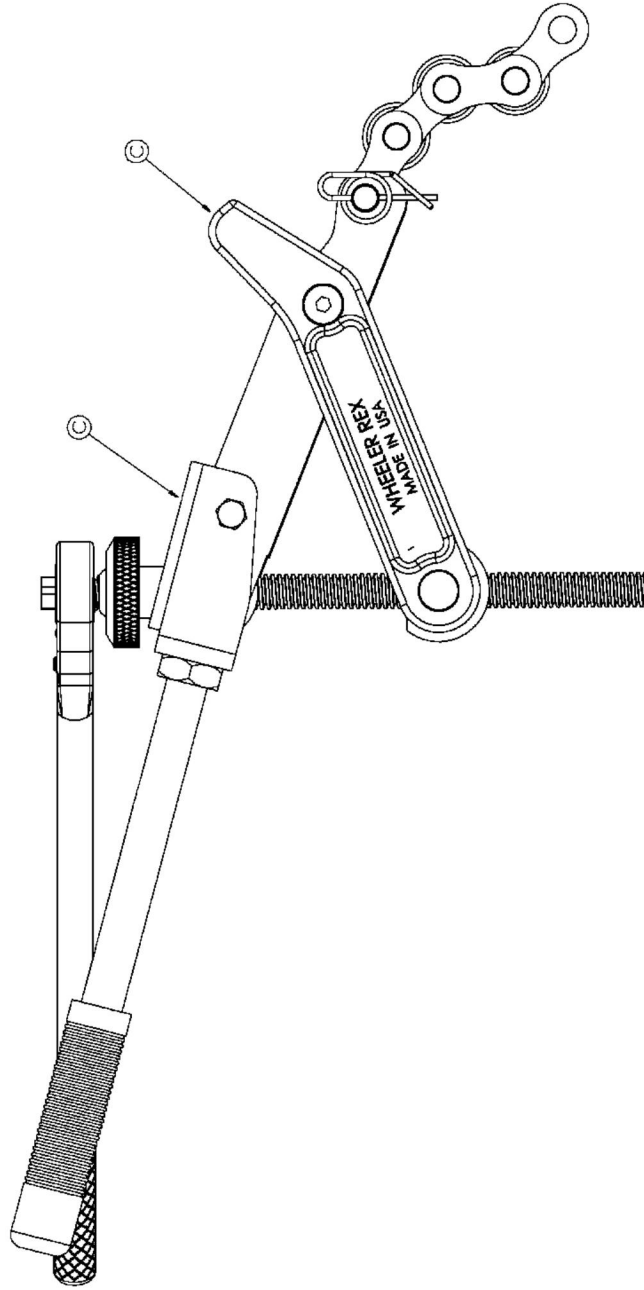
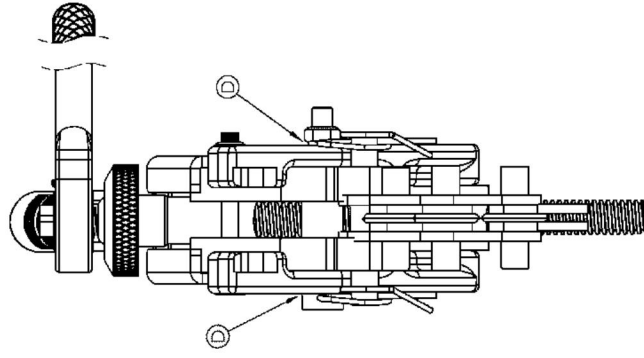

DESCRIPTION: RATCHET PIPE CUTTER  
PART NO. 39908

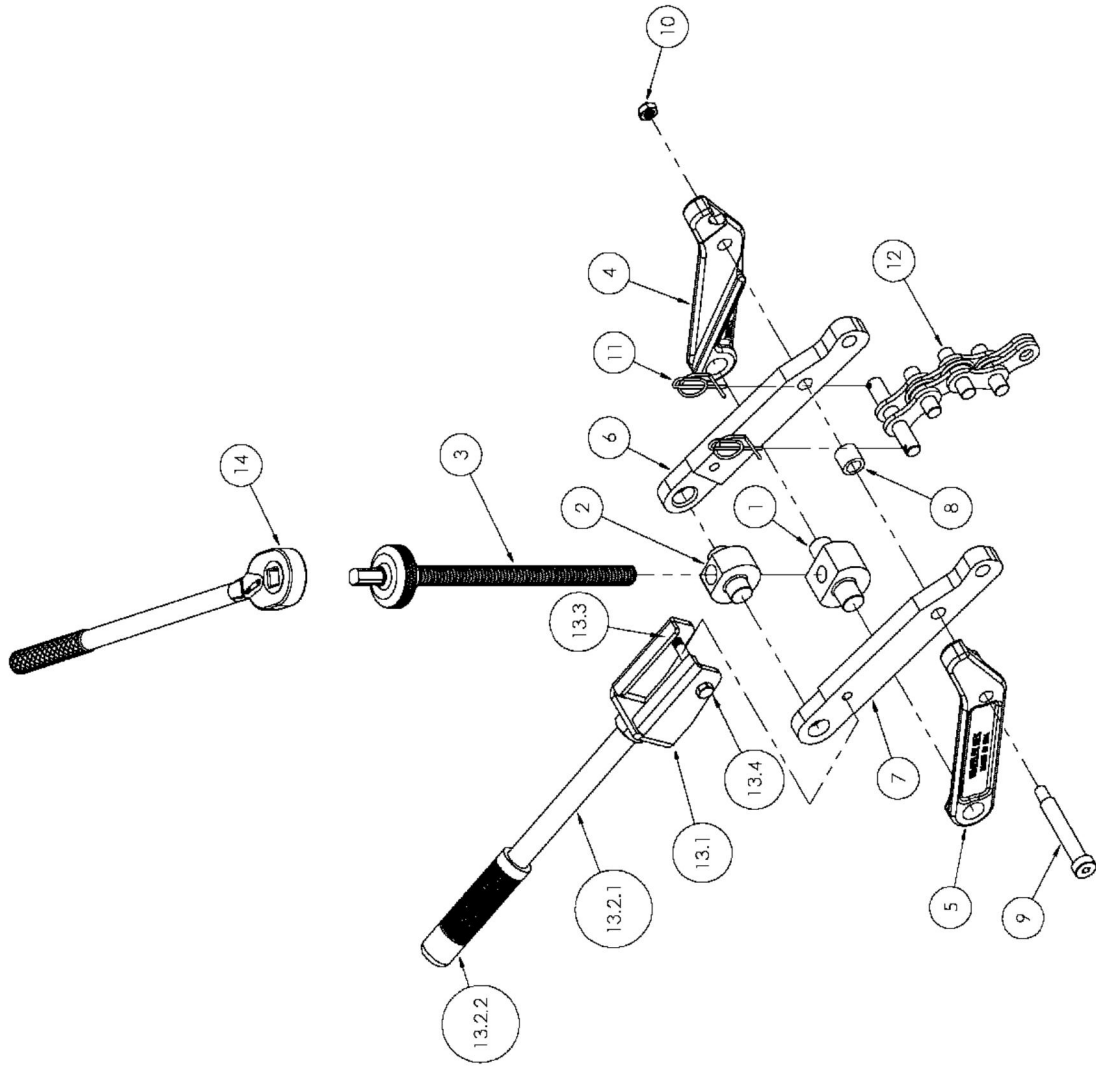

ITEM NO.	PART NUMBER	DESCRIPTION	QTY.
1	700916	LOWER TRUNION	1
2	700917	UPPER TRUNION	1
3	700919	DRIVE SCREW ASBY.	1
4	700912	LEFT HAND OUTER JAW	1
5	700913	RIGHT HAND OUTER JAW	1
6	700914	LEFT HAND INNER JAW	1
7	700915	RIGHT HAND INNER JAW	1
8	2983	JAW SPACER, LONG	1
9	275836	2 3/4" x 1/2" Socket Head Shoulder Screw	1
10	276198	3/8" Nylon-Insert Locknuts	1
11	3908	HAIR PIN CLIP	2
12	701077	8" CHAIN	1
13	701101	HANDLE ASSEMBLY	1
13.1	701100	STRAP ASSEMBLY	1
13.2	652	HANDLE ASBY	1
13.2.1	6526	HANDLE	1
13.2.2	154	GRIP	1
13.3	275857	5/16-18 Thin Hex Nylon-Insert Locknuts	1
13.4	276737	5/16"-18 x 2 3/4" HEX HEAD CAP SCREW	1
14	6520	RATCHET, 1/2" SQ. DRIVE	1



DESCRIPTION: RATCHET PIPE CUTTER  
PART NO. 39908